

CENTRAL CONTROLLER MULTI-ROOM SYSTEM

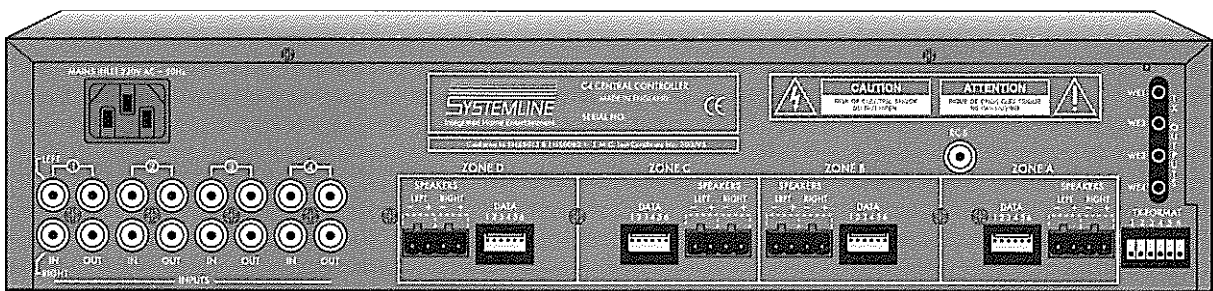

Installation Manual C4.1

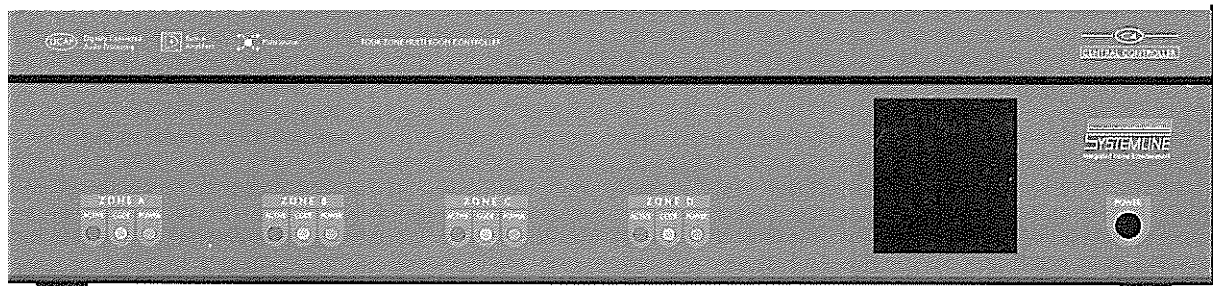



This symbol is to alert the user to the presence of dangerous voltages inside the enclosure of the Central Controller. To reduce the risk of electric shock do not remove any parts of the Central Controller.

Read all the instructions before connecting or operating the Central Controller. Pay particular attention to the safety information. Keep this manual so you can refer to these safety instructions.

WARNING: There are no user serviceable parts inside. Refer all servicing to qualified service personnel.

WARNING: To reduce the risk of fire or electric shock, do not expose the Central Controller to moisture or water. Do not allow foreign objects to get into the enclosure. If the unit is exposed to moisture, or a foreign object gets into the enclosure, immediately disconnect the power cord from the wall. Take the unit to a qualified service person for inspection and necessary repairs.

Clean the Central Controller only with a dry cloth or a vacuum cleaner.

Place the Central Controller on a fixed, level surface strong enough to support its weight. Keep the Central Controller away from radiators, heat registers, stoves, or any other appliance that produces heat.

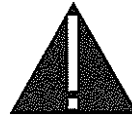

This symbol is to alert the user to important operating instructions in the owner's information accompanying the Central Controller.

If the Central Controller is placed in an enclosure, there must be sufficient ventilation of the enclosure to allow proper cooling.

Connect the Central Controller to the power outlet only with the supplied 3-pin grounded power supply cable or an exact equivalent. The cable should be connected to a properly grounded 3pin wall outlet. Do not modify the supplied cable in any way. Do not use extension cords.

Do not route the power cord where it will be crushed, pinched, bent at severe angles, exposed to heat, or damaged in any way. If the cable shows any sign of wear or damage, immediately stop using it and obtain a proper replacement from a qualified service agency or from the Systemline service department.

If the Central Controller shows signs of improper operation, or if it has been dropped or damaged in any way, immediately disconnect the power cord from the wall. Take the Central Controller to a qualified service person for inspection and necessary repairs.

GUARANTEE

All products are covered by a 2 year guarantee for parts and labour. Site visits are not covered by this guarantee and will normally result in a call out charge if such a visit is requested or deemed necessary.

1	System Overview	1	5	System Set-up	17
1.1	Basic Architecture	1	5.1	IR System and Control Codes	17
1.2	Controlling the Remote Zones	1	5.11	Overview	17
1.3	Systemline Packages	1	5.12	Front Panel IR Flood Emitter	17
1.4	Systemline Highlights for Installers	1	5.13	Rear Panel IR Emitters	17
			5.14	Rear Panel RC-5 Connection	17
2	Component Description	3	5.2	Advanced Multi-Zone Systems	18
2.1	Central Controller	3	5.21	Eight & Twelve Zone Systems	18
2.2	SC-FH Basic Function Handset	4	5.22	Large System Configuration	18
2.3	SC-LH Full Function 'Learning' Handset	4	5.23	Source Connections	18
2.4	IMS Display/Eye	5	5.24	IR Flood Emitter Connections	19
2.5	Data Cable and Connectors	5	5.25	IR Repeater Connections	20
2.6	Speaker and Cable Connections	5	5.26	Note on "Engaged" Indicator	20
3	System Planning	6	6	Operation	21
3.1	Initial Considerations	6	6.1	Preliminary Observations	21
3.2	Source Components MultiRoom Suitability	6	6.2	System Start-up	21
3.21	What to Look for	6	6.3	System Status	22
3.22	General Notes	7	6.31	Engaged Indication	22
3.3	Central Controller Basic Set-up	8	6.4	Teaching the SC-LH Learning Handset	23
3.31	Placement	8	6.41	Using the Learning Handset	24
3.32	Connections	8	6.5	Operating Components Via Systemline	25
3.33	IR "Flood" Emitter	9	6.51	Using the Tuner	25
3.34	IR Emitter Jacks & Cabling	9	6.52	Using the CD Multi-Player	25
3.35	RC-5 Direct Connection	9	6.53	Using an A/V Source (e.g. Satellite Receiver)	25
3.4	Zone Configuration	9	6.6	Using the SC-FH Basic Function Handset	26
3.41	Basic Zone Complement	9	6.61	Key Operating Points	26
3.42	Display/Eyes	9	6.7	IMS Display/Eye	26
3.43	Loudspeakers	9	6.71	Overview	26
3.5	A/V Wiring	10	7	Conclusion	27
3.51	Recommended Wiring...	10			
4	Installation Guide	11			
4.1	The Central Controller	11		Appendix A	28
4.11	Source Connections	11		QED Fax Back	28
4.12	Speaker Cable Connections	12			
4.13	Data Cable Connections	13			
4.2	Zone Control Devices	14			
4.21	IMS Display/Eye	14			
4.22	Fitting IMS Modules...	15			
4.3	Zone Connection Strategies	16			

1.1 Basic Architecture

The Systemline Central Controller Multi-Room Control System distributes audio signals from a single set of source components to as many as four separately controlled remote zones or listening areas. The Central Controller contains source selection, microprocessor controlled communications circuitry and independent preamplifier/power amplifier sections for all zones.

1.2 Controlling the Remote Zones

Users can select one of two ways to control remote zone operation. The first is using the SC-FH Fixed code handset which generates infra-red codes. The codes are then read by the wall mounted IMS Display/Eye and conveyed via a hard-wired connection to the C4 Controller. The SCFH only generates codes that are recognized by the Controller: namely, volume up/down, zone on/off, and source selection. The original handset supplied with the source equipment may also be used via the infra-red link to provide full function control.

The second method uses the SC-LH Learning handset which offers full function control of not only source selection and volume, but also such functions as play, skip, fast forward and stop.

Up to two IMS Display/Eyes may be specified per zone.

1.3 Systemline Packages

SCP-4A Contains:

1 x C4 Central Controller, 4 x IMS Display/Eyes and 1 x SC-FH Basic Remote Control Handset (Order face plates separately)

SCP-4X Contains:

1 x C4 Central Controller, 4 x IMS Display/Eyes, 1 x SC-FH Basic Remote Control Handset, 2 x SC-LH Full Function Learning Handsets and 4 Pairs of CS230LP Hi-Fi Standard Ceiling Speakers (Order face plates separately)

1.4 System Highlights for Installers

- 1) 2 Display/Eyes can be connected to any one zone simply by connecting one to the other!
- 2) All Eyes are interchangeable for easy installation. Simply set the DIP switch on the Eye to the zone address.
- 3) All zones can be put into Standby with a single command: just hold the Standby Button down for 4 seconds or more.
- 4) The System incorporates a near Universal Infra-red Link. Simply point any remote at an IMS to relay the command back to the source components.
- 5) Four Infra-red 'Window Emitters' can be plugged directly into dedicated mini jack sockets.
- 6) Components featuring an RC-5 bus can be plugged directly into a dedicated RC-5 output.
- 7) The TX configuration terminal allows up to 3 controllers to be linked together, and still use just one set of IR Emitters.

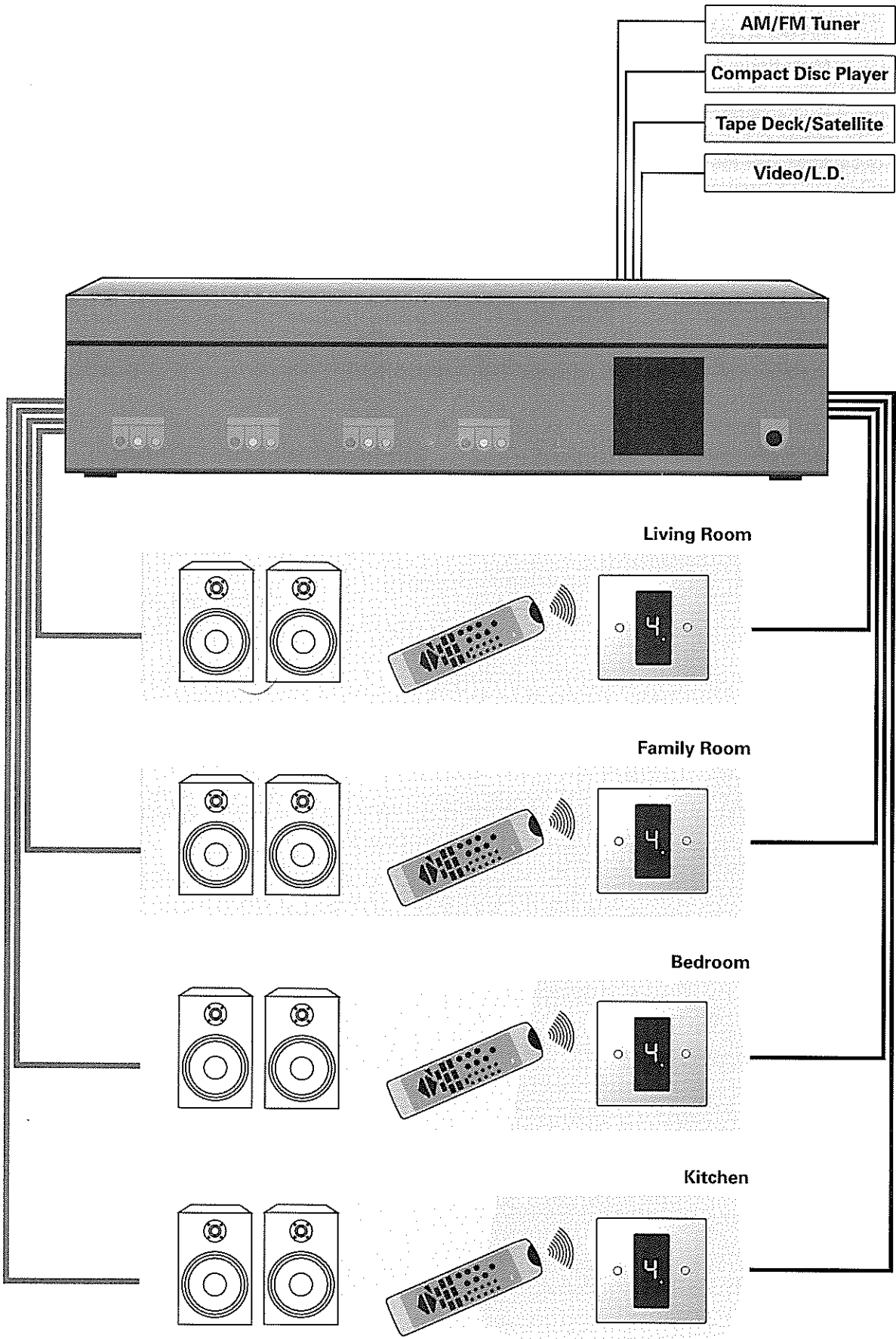

2.1 Central Controller

The Central Controller is the heart of the Multi-Room Control System. It features:

- Four separate microprocessor-controlled stereo preamplifier/power amplifier sections, one for each remote zone
- PHONO inputs for up to four sources
- "Loop through" PHONO outputs which allow these sources to connect directly to an additional entertainment system if desired
- Quick Fit speaker plugs and sockets
- Control data input for each zone via industry-standard 6 pin IDC/Methodé connectors (supplied)
- PHONO output for RC-5 remote control protocol components (Direct connection via RC-5 bus)
- Four mini-jack IR emitter outputs
- High-power front panel IR "Flood" emitter to transmit remote zone commands to associated source components

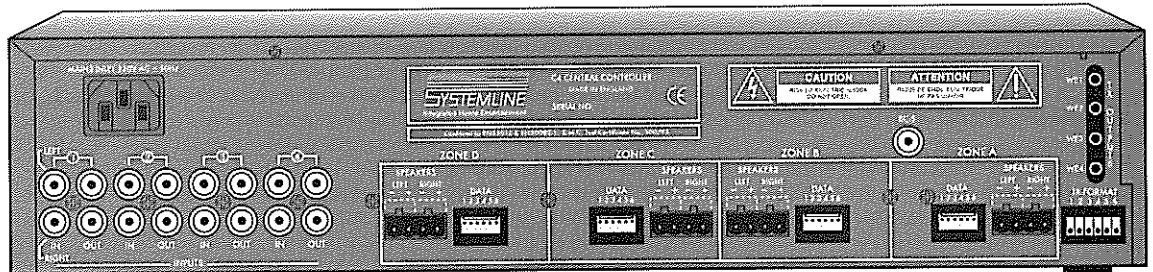

2.2 SC-FH Basic Function Handset

The SC-FH is the simplest remote control handset that we manufacture. It will control only source selection, room on/off and, volume up/down - ideal for children's rooms, or where absolute simplicity is essential.



2.3 SC-LH Full Function Learning Handset

For full function control of up to six pieces of equipment-typically Satellite (or cable), Video, TV, CD, Tuner and Tape. The SC-LH Learning handset is pre-programmed to operate both the Systemline C4 Central Controller and Philips/Marantz brand products. It can, however, be taught alternative codes to operate many other brands of equipment.

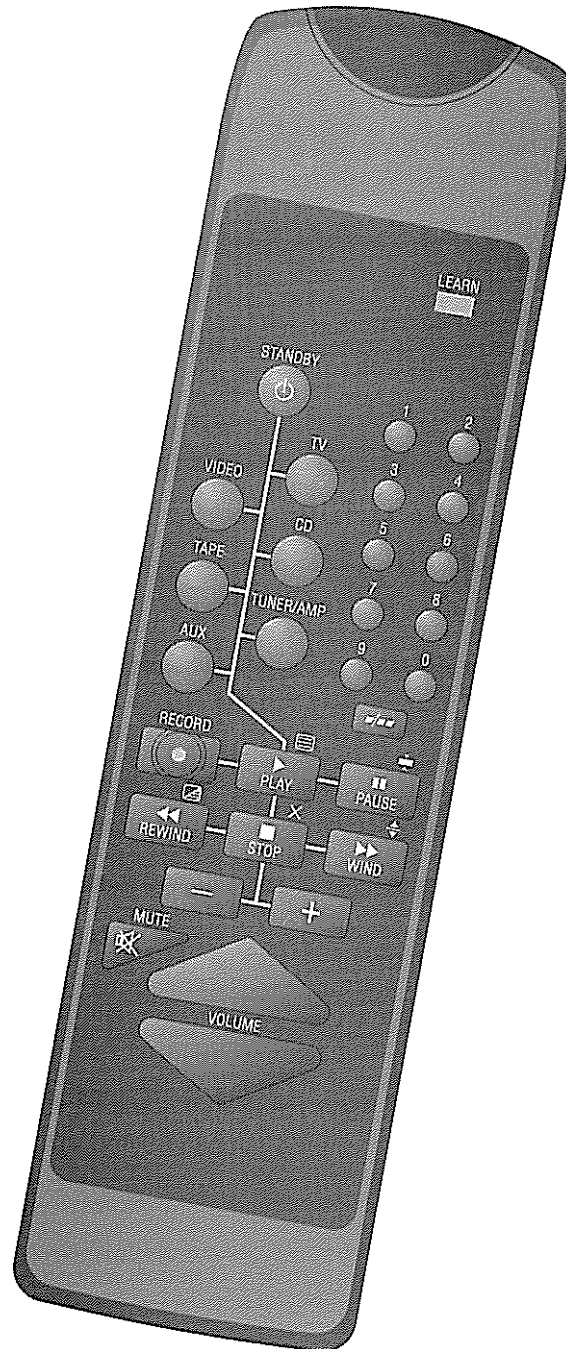

2.4 IMS Display/Eye

The wall-mounted IMS Display/Eye receives commands from either the SC-FH or SC-LH hand held remote and, after processing to ensure maximum data integrity, sends these codes to the Central Controller. In addition, the IMS provides a continuous system status check at each remote location by displaying a range of easily-understood alphanumeric characters. You'll find details in sections 4.2 & 6.

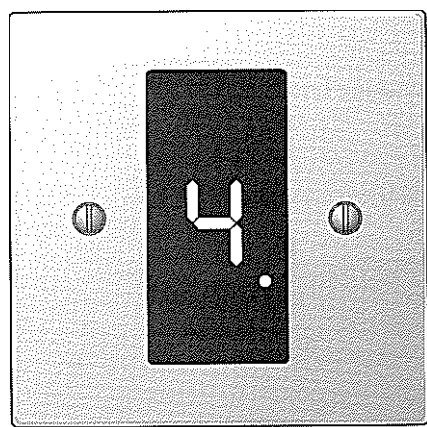

2.5 Data Cable and Connectors

The data path between the Central Controller and IMS Display/Eyes must be made with cable with six conductors plus a braided outer shield. We recommend Systemline Cable SL-C for best results. Other six conductor + shield cable may be perfectly acceptable but the Central Controller system data connectors work only with cables using 24 gauge conductors. Make sure that all data cables conform to this requirement.

Data cable termination is via industry-standard 6 pin connectors made by Methode and others. (The Methode part number is 1300-106-424.) Pin-out configuration and termination hints are found in Section 4.13.

2.6 Speaker and Cable Connections

Unshielded two conductor 42 Strand QED speaker cable is the minimum acceptable standard for connections between the Central Controller and zone loudspeakers. For particularly long runs or where there is a requirement for the best possible sound quality, QED Qudos Speaker Cable should be used.

The Central Controller amplifier outputs are connected via quick fit 2 way speaker plugs with screw terminal connection. These connectors are suitable for wire gauges up to 2.5mm².

3.1 Initial Considerations

The Central Controller can be used in either of two basic ways.

- a) As a stand-alone control centre for a multi-zone distribution system using dedicated source components.

- b) As a control centre that shares source components with an existing music or home theatre system.

Specific system configurations will determine the best location for the Central Controller (See Section 3.3).

3.2 Source Components MultiRoom Suitability

3.21 What to Look for

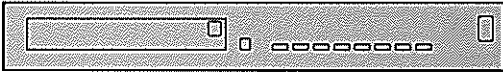
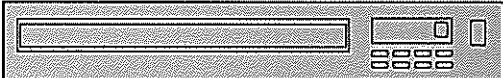
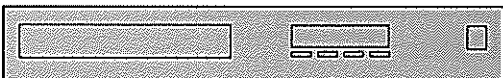
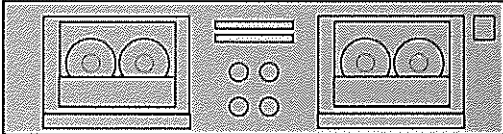
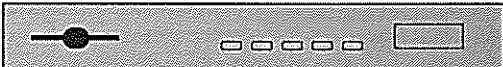
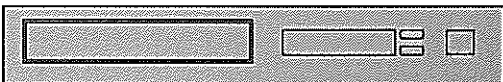
Radio Tuner		✓✓✓✓✓
Multi Disc CD		✓✓✓✓✓
Single Disc CD		✓✓✓
Tape		✓✓
Satellite Receiver		✓✓✓✓✓
Video		✓✓✓

Tuners

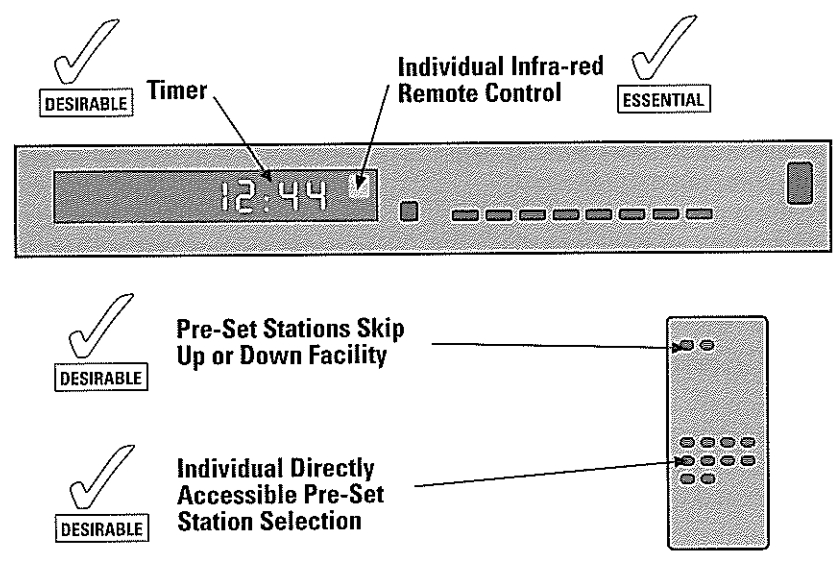

Multi CD Players

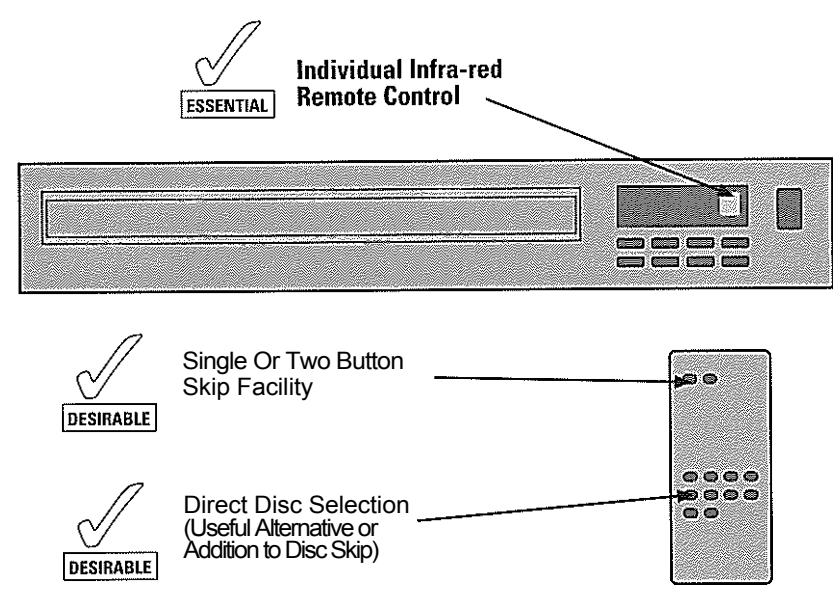

3.22 General Notes

It is not uncommon for a remote control handset supplied with a tuner or CD player to have only direct pre-set channel selection or direct disc selection. However, by investigating other handsets within the same manufacturer's range, typically the Receiver and System handsets, the missing Pre-Set Channel Skip and Disc Skip can be found. Yamaha (tuner) and Pioneer (CD players) are good examples of this.

Generally speaking avoid midi systems for use with Systemline or any infra-red data bus connected systems that only permit one source to be on at any given time. The SC-LH Learning Handset is pre-programmed for RC-5* codes, so choosing a brand that operates on that code system (Marantz, Arcam, etc.) will avoid any potential compatibility problems.

*RC-5 is a recognized infra-red code set devised by Philips and used by a number of companies.

3.3 Central Controller Basic Set-up

the main Hi-Fi system, the central location point could be anywhere-hidden in a cabinet in the hall or even under the staircase-the only access required is to change discs or tapes (See also Section 3.5 A/V Wiring).

3.3.1 Placement

The Central Controller is designed to cosmetically complement high quality home entertainment components. Place it on a stable surface in an equipment rack or cabinet. Note that the Central Controller is

slightly deeper than most sources (tuners, CD players, cassette decks, etc.) and should not generally be placed on top of these units.

The exact location may be governed by existing wiring such as Satellite or TV points or be determined by the loca-

tion of the existing Hi-Fi system. In which case, the central location point will probably be in the lounge or family room. Alternatively, if the Multi-room System is to operate separately from (or instead of)

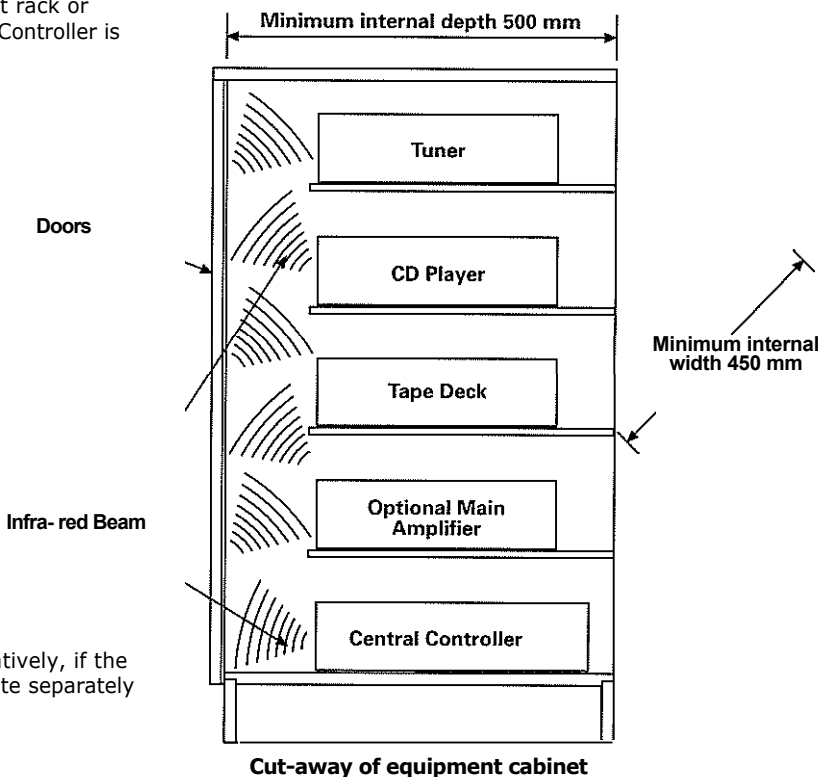

3.3.2 Connections:

Make sure that you have enough room to run all the connecting cables and dress them appropriately behind the Central Controller. Although we'll explain each connection fully in following sections of this manual, take a quick glance through the following list of possibilities and decide how much space you'll need. Also remember that these cables will make the Central Controller much more difficult to move when they are connected. Plan accordingly.

- a) Four pairs of PHONO to PHONO interconnects-one from each source.
- b) Four more pairs of PHONO to PHONO interconnect cables-one each to the appropriate input of the main system's preamplifier, etc., from the corresponding "loop through" output on the Central Controller (These will not be needed if the Central Controller is used as a standalone Controller).
- c) Up to eight QED speaker cable pairs (two for each zone) terminated with quick fit plugs.
- d) Four six-conductor+shield (SL-C) data cables, each terminated with the proper IDC connector.
- e) One shielded PHONO to PHONO interconnect for RC-5 remote control code connection (if required).
- f) Up to four IR Window Emitters for connection to the Central Controller's TX Infrared outputs (if required).
- g) Additional PHONO to PHONO shielded cables and loudspeaker connections as required for systems using more than one Central Controller amplifier.

- h) Up to six "TX-FORMAT" terminal block jumper wires needed when cascading multiple Central Controllers

We STRONGLY RECOMMEND that you attach a tag or strip to each cable and wire that permanently and positively identifies it. This will help in any required troubleshooting immediately after the installation as well as make future service calls or system add-ons much less frustrating.

Avoid vague identifiers ("Tape Deck," for example) in favour of carefully defined lines such as "To Input 3 from tape deck." However well you remember each installation just after completing it, you WILL FORGET by the next time you see it again.

3.33 IR "Flood" Emitter

The Central Controller has a high intensity front panel IR "flood" emitter designed to transmit commands from the remote zones to the appropriate source component. Although exact performance will vary, this high power transmitter has an effective operating range of approximately 6 Metres under normal conditions.

If the Central Controller is on an open shelf, the emitter's signal must first travel to an IR-reflective surface (an opposing wall, for example) and then to the source component.

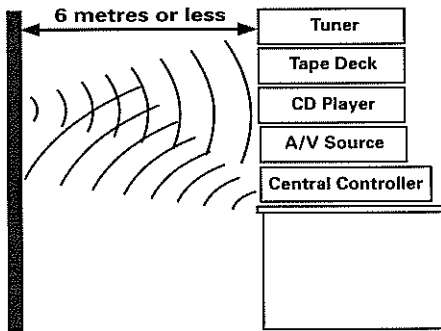

Keep total IR signal travel to 12 Metres or less. Remember that it must travel to a hard reflective surface and then back again.

3.34 IR Emitter Jacks & Cabling

Remember that the Central Controller also has four rear panel IR output jacks for use with IR Window Emitters. Use these in situations where output from the front panel "Flood" IR emitter is blocked from the source components by a door, full depth shelf, etc.

3.35 R.C.5 Direct Connection

For any source equipment fitted with an R.C.5 data bus socket, a "hard-wired" connection may be made via the RC-5 phono socket on the back panel of the Central Controller. This avoids any infra-red retransmission.

3.4 Zone Configuration

3.41 Basic Zone Complement

Each remote zone includes at least one Display/Eye and a pair of loudspeakers.

3.42 Display/Eyes

The IMS Display/Eye reads infra-red signals generated by the SC-RH or SC-LH hand-held remote controls and, after translating them into a digital code that is highly resistant to interference, sends them to the Central Controller.

Remember that the IMS Display/Eye also provides visual clues to total system operation (Details are found in Section 6.3).

3.43 Loudspeakers

These will vary with installation requirements and user expectations. The Central Controller's amplifier sections are optimized for impedance loads of four (4) ohms or higher.

CS230LP Systemline Hi-Fi Ceiling Speakers are now available. Please ask for details.

3.5 A/V Wiring

3.51 Recommended Wiring Configuration For Video & Satellite Distribution.

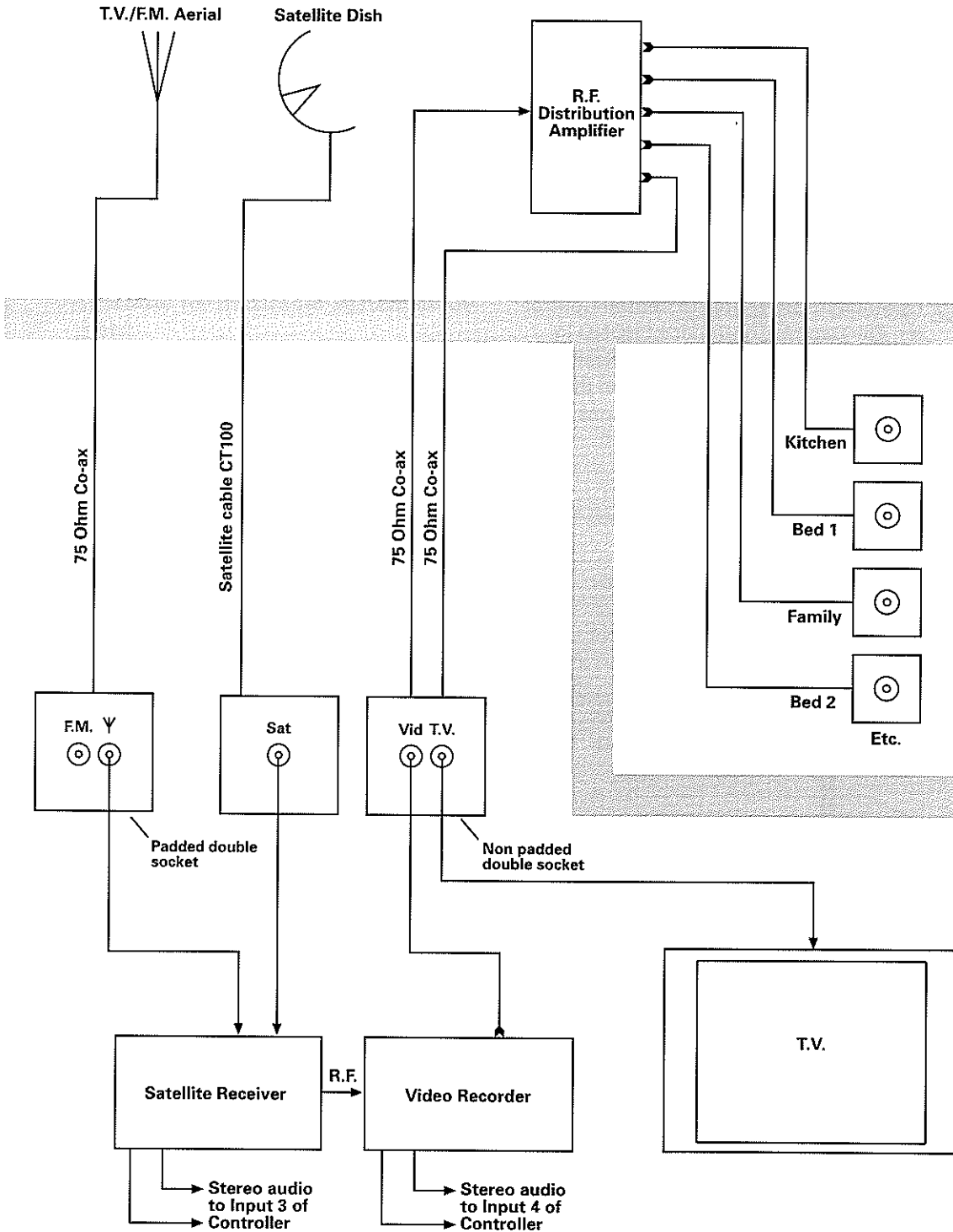

4.1 The Central Controller

4.1.1 Source Connections

Connect LINE LEVEL sources (CD player, tuner, etc.) to the Central Controller's rear panel as follows.

- a) Using shielded PHONO-PHONO cables, connect the source's output to the corresponding input on the Central Controller. Connect analog outputs from the source components as indicated to assure clear operation with either hand-held remote.

Tuner	Input 1
CD player	Input 2
Tape Deck/Sat. receiver	Input 3
Video/Laser disc	Input 4

Make sure to observe correct channel continuity from source to Central Controller. The Central Controller's PHONO inputs are labelled for easy identification with Left Channel connections on the top row and Right Channel connections on the bottom row.

NOTE 1: The Central Controller does not accept a phono cartridge's output directly. If required, use a separate phono preamp (such as QED Discsaver) to boost phono signal to line level.

NOTE 2: To simplify system operation, we strongly suggest using only FIXED LEVEL source outputs to the Central Controller. If no FIXED LEVEL outputs are available, use variable outputs but make sure that the source component's level control is turned up sufficiently but not so high as to overload the Central Controller's inputs.

- b) If the source is shared by another system, connect the appropriate Central Controller source output to the appropriate input of the main system's preamplifier, etc.

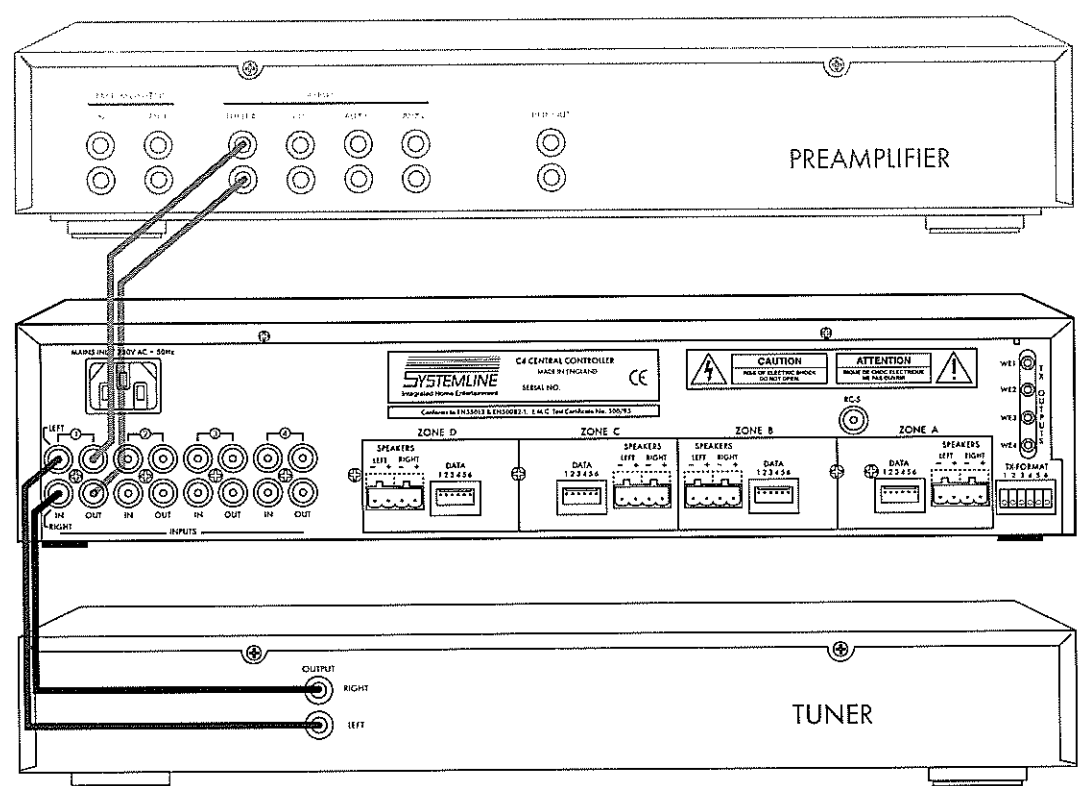

Tuner connected to Source 1 input with optional pass-through to preamp for shared use with separate system.

4.12 Speaker Cable Connections

NOTE: These Zone Connection instructions focus on one zone only. Connections for all other zones are identical except for the mirror-image connector placement on alternate zones.

Use the supplied quick fit terminals for all speaker cable connections.

Strip back each conductor's outer insulation by 6mm, Insert bare wire into quick fit plug and secure using the screw terminal fixing. Take care to ensure proper polarity (note "+" is normally identified by a fine rib running along one edge)

BE CAREFUL AND BE PATIENT. This is an admittedly tedious task, particularly when you are hooking up speakers for all four zones, but it is essential for maximum system enjoyment.

"Out of phase" loudspeaker hookups (where one speaker in a stereo pair is inadvertently connected "+" to "-" and vice versa) may not be immediately noticeable but will not be as pleasing in the long term as a properly connected stereo pair.

The long runs from amplifier to speaker typically found in multi-zone installations demand heavy gauge, low resistance speaker wire. Small diameter wire reduces effective amplifier power and adds substantial distortion to the audio signal. Avoid problems by following these minimum recommendations:

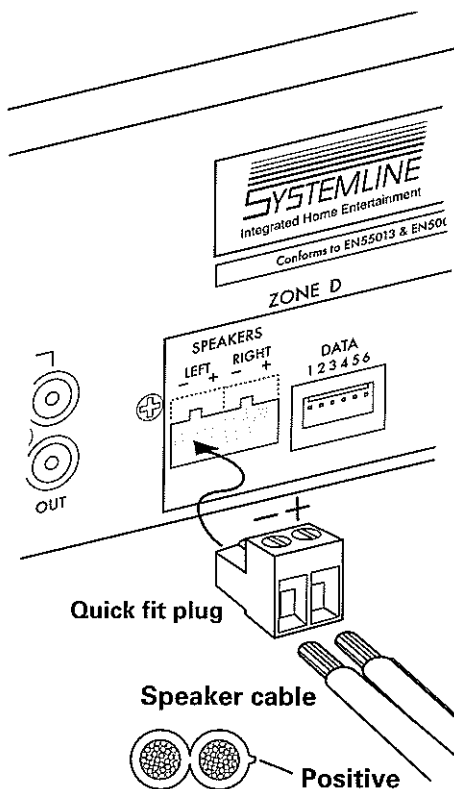

Under 20 m	=>	QED 42 STRAND 0.75mm (minimum)
More than 20 m		QED QUDOS 2.5mm

Loudspeaker runs over 100 m are discouraged.

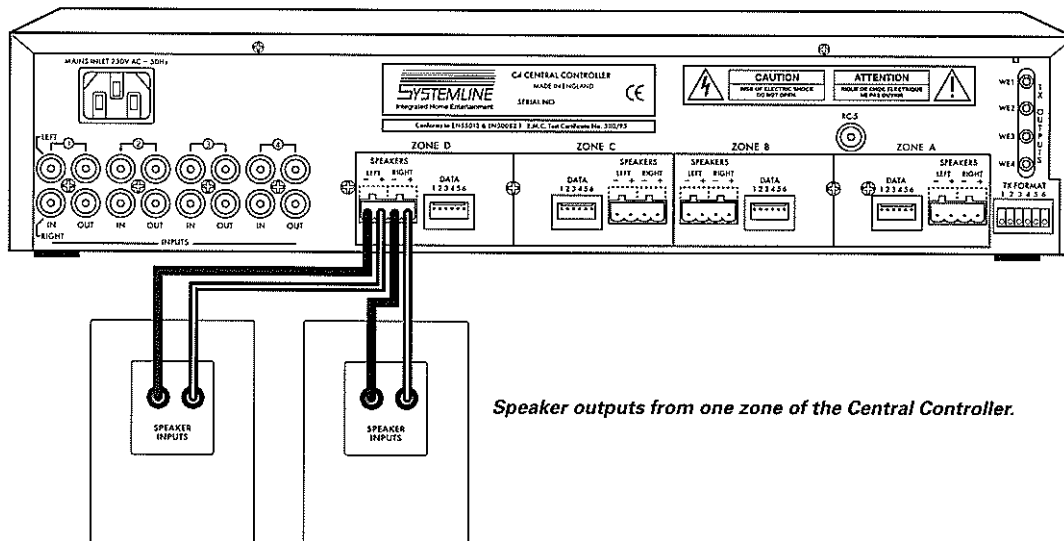

Speaker outputs from one zone of the Central Controller.

4.13 Data Cable Connections

Data communication to and from the Central Controller and the remote zone's IMS Display/Eyes is via 6 conductor shielded cable. We recommend QED Systemline Cable. (Note that the IDC connectors only accept cable with 24 gauge conductors.)

We also recommend that you run each zone's data cable and speaker cables together to save time. There is absolutely no performance penalty for doing so.

The shield is absolutely essential in maintaining data integrity over the long runs between the controller/amplifier and a zone's control code generating devices. Make sure that the shield is firmly connected at both the Central Controller and at the IMS Display/Eye.

NOTE: Only one data cable needs to run from the Central Controller to each zone. Multiple Display/Eye combinations in one zone should be wired via series connections detailed in Section 4.3.

DATA CONNECTOR WIRING CODE

- Pin 1 • black & shield
- Pin 2 • white
- Pin 3 • red
- Pin 4 • brown
- Pin 5 • blue
- Pin 6 • green

Connections are made in the same order at both ends of the cables.

WARNING: ONLY USE CORRECT IDC TOOL (SL-IDC)



NOTE: Do not use a screwdriver, metal ruler or knife blade to "crimp" these connections. You may think these tools will work but you will be mistaken. USE THE DEDICATED IDC TOOL SPECIFICALLY DESIGNED FOR THESE CONNECTORS.

- Strip about 40 to 50 mm of the outer cable insulation using a wire stripper, cutting pliers, or a sharp knife.
- Separate the braided outer shield wires from the conductors and twist them into one "pig-tail."
- DO NOT strip insulation off the six individual conductors as the connector automatically makes contact with the conductor core when crimped.
- Place the shield pig-tail into slot 1 (left hand side) of the connector and press down *lightly* with the crimping tool to hold it in place.

Place the BLACK conductor immediately on top of the shield pig-tail in slot 1, hold it in place and push down harder with the crimping tool until you hear a slight "click".

The shielded pig-tail and black-insulated conductor should now be locked into slot 1. (The clicking sound also tells you that the connector slot contacts have pierced the conductor's insulation.) Test the connection by pulling gently on both shield and conductor.

- Continue the process following the colour code guide above until all other conductors are locked in the appropriate connector slots. Remember that slot 1 is the ONLY ONE to get both the shield and a conductor. All other slots receive a single conductor.

After attaching the cable conductors to the connector, snap it onto the appropriate zone's 6 pin data terminal on the Central Controller's rear panel. Be careful to centre the connector over the terminal pins before inserting.

The maximum data cable length for guaranteed operation is 100 mts. Even longer lengths may be practical in some installations with low RF (Radio Frequency) and EMI (Electro-magnetic interference).

Connectors for the IMS Display/Eyes should be wired to follow the same color coding.

The supplied IDC/Methode connectors need to be 'crimped' to lock to the data cable's 24 gauge conductors. IDC tools are available separately.

4.2 Zone Control Devices

4.2.1 IMS Display/Eye

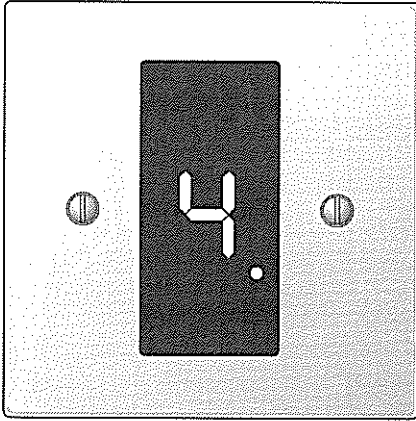

- a) The IMS Display/Eye mounts in a single 46mm deep wall box, MK type 877ZK or similar single box. The earth terminal on the wall box should be connected to mains earth NOT the shielded "pig tail"

PLACEMENT SUGGESTIONS: Exact placement will vary with each installation but we strongly recommend **AGAINST** placement where the IMS will be exposed to direct sunlight, powerful fluorescent light or the output of a high intensity spotlight, etc. These light sources contain high levels of infra-red energy and may cause intermittent operation by saturating the IMS.

Also, avoid infra-red "loops" by making sure that an IMS Display/Eye is *not* placed where it might pick up signals from a source component's IR repeater or the Central Controller's IR "flood" emitter.

Lastly, make sure that each IMS is on a relatively uninterrupted "line-of-sight" path to all likely locations from which the hand held remote might be used. You'll find the Systemline IR link much less susceptible to signal interference than other IR remote control links but conservative planning will ensure dependable operation under an even wider variety of conditions.

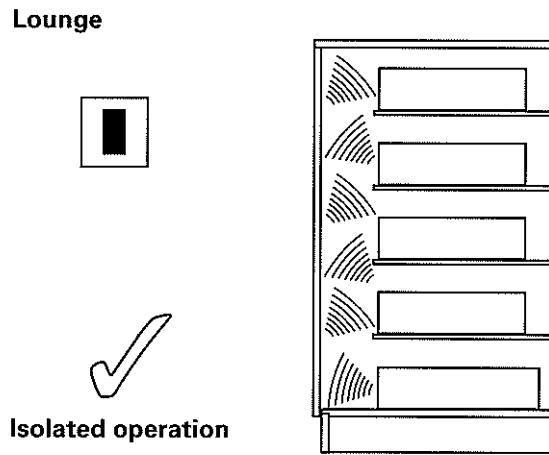
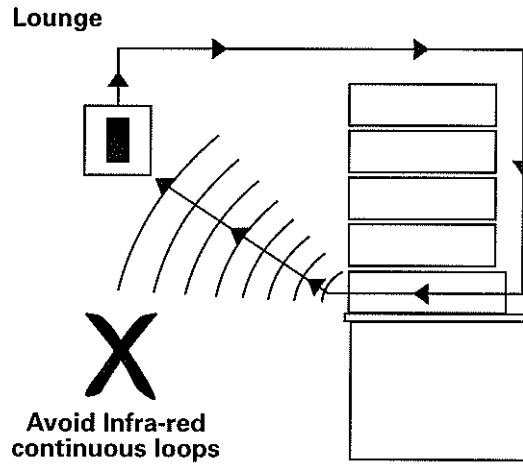

INSTALLATION NOTE: The IMS's IN and OUT data cable terminals will be at the "top" and the DIP switches at the "bottom" of the board when the IMS is properly installed.

- b) Each IMS *must* be set for the particular zone it is operating in. Set zone IDs by adjusting the IMS's board-mounted DIP switches as follows:

When setting the DIP switches, we suggest orientating the IMS so that the printed IDs on the circuit board can be easily read. After setting both DIP switches for the intended zone, invert the IMS before installing it in the box or the alphanumeric display will be upside down.

Note: Improper switch settings will not interfere with data communication TO the Central Controller so zone operations will be unaffected. However, improper switch settings will cause the IMS to display inaccurate and confusing system status information.

- c) Data cable terminations and connections are made the same way as previously detailed in Section 4.13. Note that each IMS has two data terminals labelled "IN" and "OUT" respectively (See Section 4.3 for zone connection strategies)

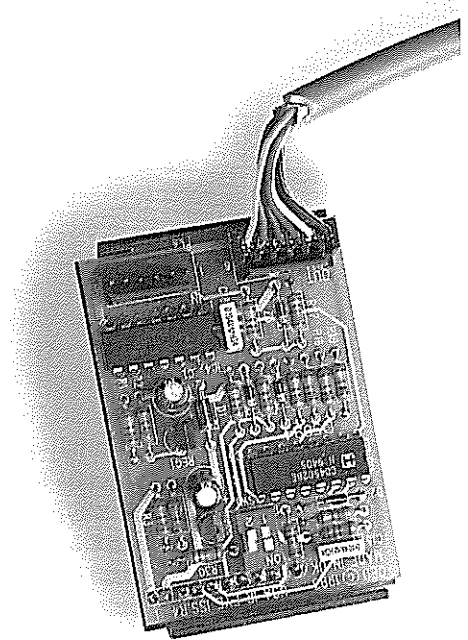

Zone switches

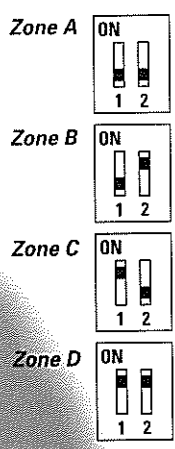
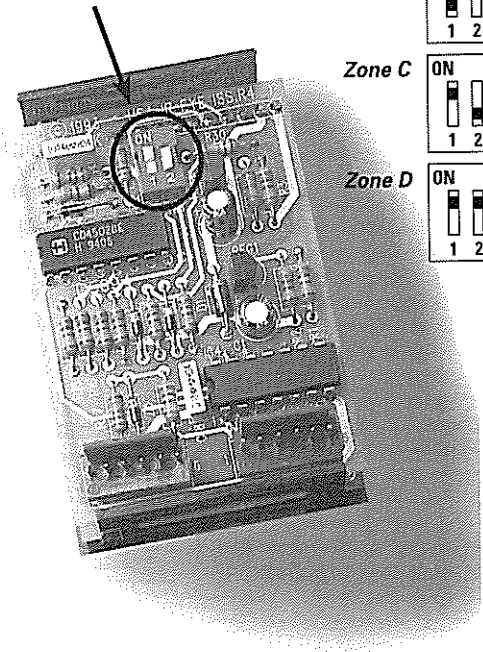

4.22 Fitting IMS Modules into Back Box & Wall Plates

To fit an IMS module into a single gang back box, it is first necessary to bend back the top and bottom lugs to allow access.

To fit an IMS module onto a wall plate, simply peel off the protective strips along either side of the module and stick the module firmly to the back of the wall plate.

4.3 Zone Connection Strategies

- a) Each zone will support two IMSs and each IMS signals when it receives and processes a command. All the command devices for one zone should connect to each other in serial fashion using their appropriate circuit board-mounted "IN" and "OUT" terminals.

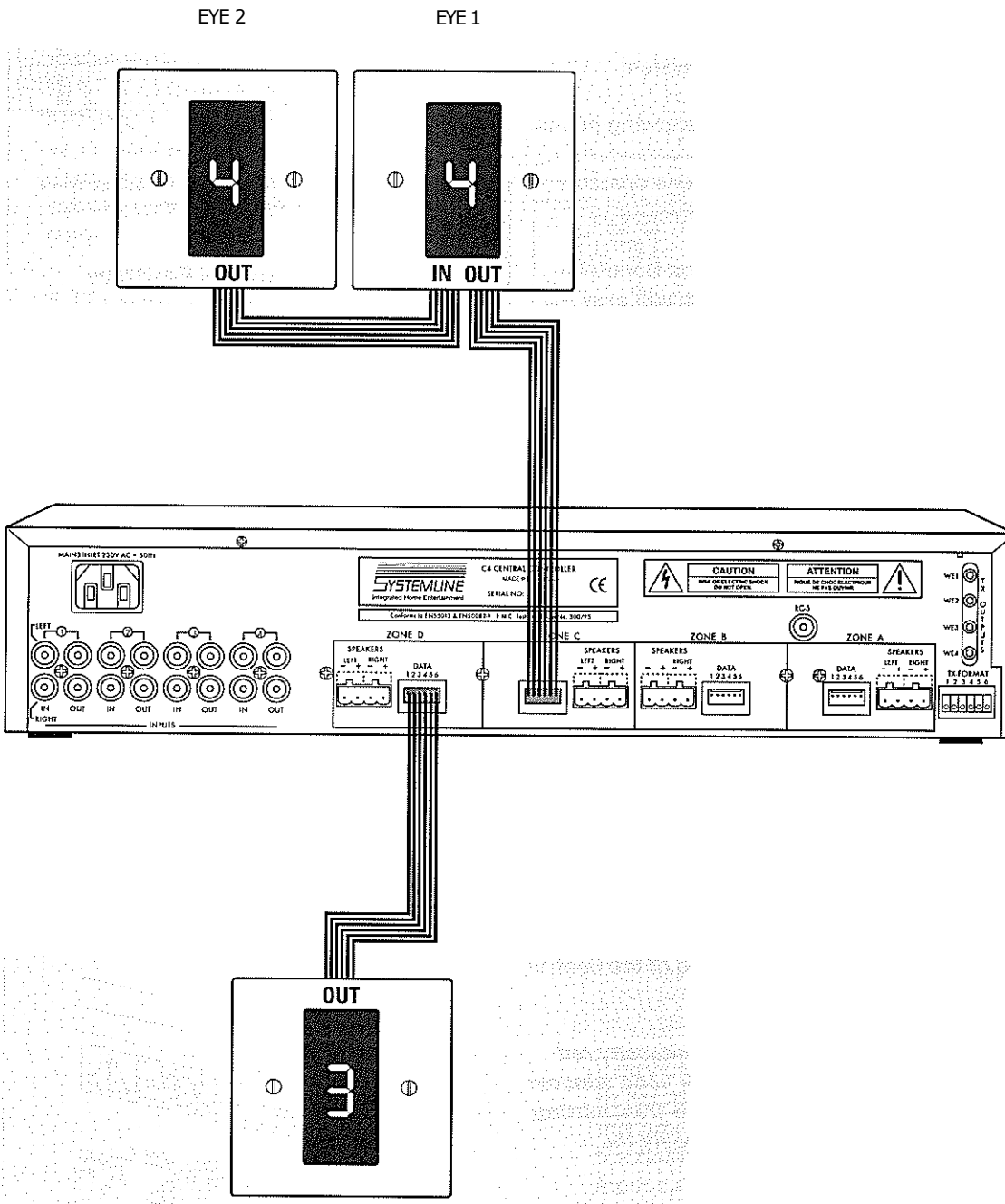

5.1 IR System and Control Codes

5.11 Overview

The Central Controller's IR system provides extensive remote control flexibility. With the possible exception of the points in Sections 5.22 and 5.23, nothing needs to be done to set up the IR system.

However, please note the following points:

- a) The IR link from a remote zone operates ONLY when that zone is active.
- b) In addition to passing Central Controller system codes, the IR system will pass ALMOST any IR code sequence from an IMS to a source component. This allows you to control many popular equipment brands. (The few exceptions use a non-standard IR transmission frequency.)

5.12 Front Panel IR Flood Emitter

All Central Controllers are shipped with the front panel IR "flood" emitter engaged. However, there may be applications (system installations on open shelves in very large, bright rooms, for example) where the IR "flood" emitter might interfere with proper source component operation or will not be particularly effective in communicating control pulses.

To disable the IR "flood" emitter, remove the jumper wire between screws 2 and 3 of the TX FORMAT terminal block located on the lower right hand side of the Central Controller's rear panel.

NOTE: There is a very low intensity red LED mounted behind the IR flood window which flashes whenever it is transmitting IR codes. Use this LED to verify the emitter's operating status.

Optional remote IR emitters for use in lieu of front panel IR flood emitter.

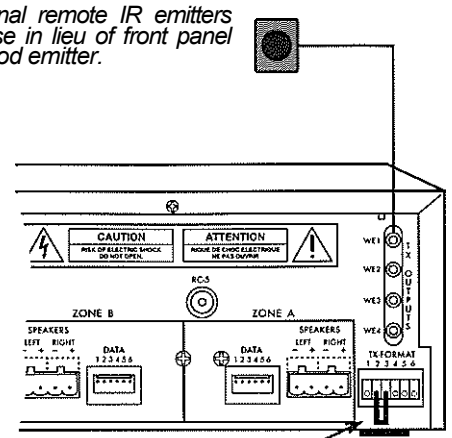

Remove this jumper to disable front panel IR flood emitter.

5.13 Rear Panel IR Emitters

The Central Controller rear panel has four paralleled 3.5 mm mini-jack sockets labeled 'TX OUTPUTS'. These accept the QED Window Emitters (Order Code RL-WE).

Use these optional IR Window Emitters in situations where the Central Controller will be located some distance away from the source components or where the IR "flood" emitter may have difficulty transmitting reliable source control data.

5.14 Rear Panel RC-5 Connection

For any source equipment fitted with an RC-5 data bus socket, a "hard-wired" connection may be made via the RC-5 PHONO socket on the back panel of the Central Controller. This avoids any infrared retransmission.

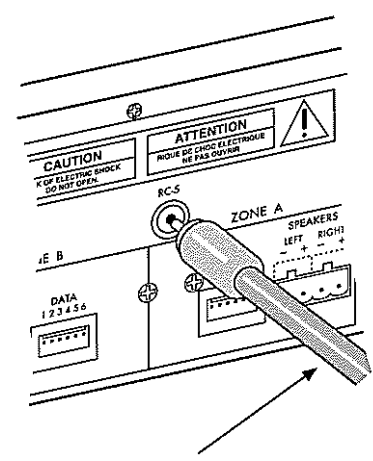

Screened PHONO to PHONO cable.

5.2 Advanced Multi-Zone Systems

5.21 Eight & Twelve Zone Systems

The Central Controller is designed to supply independently controlled sound to four separate zones. In rare instances, a complex system may require even more flexibility. To satisfy these requirements, up to three Central Controllers can be cascaded to form a system with as many as 12 independent zones. Under these circumstances, all Central Controllers can still use only one set of source components.

5.22 Large System Configuration

When system complexity calls for more than one Central Controller, ensure that no more than 3 Controllers are stacked on top of one another.

All hookup instructions will assume that Zones 1-4 will be handled by the bottom Central Controller (called "A"), Zones 5-8 from the Central Controller immediately above it ("B") and Zones 9-12 by the top unit ("C").

5.23 Source Connections

Connect all sources to the first Central Controller ("A") per the instructions in Section 4.11. Using shielded PHONOPHONO cables, connect Source 1's "loop through" outputs on Central Controller "A" to the corresponding Source 1 input on Central Controller "B". Follow this procedure for all inputs.

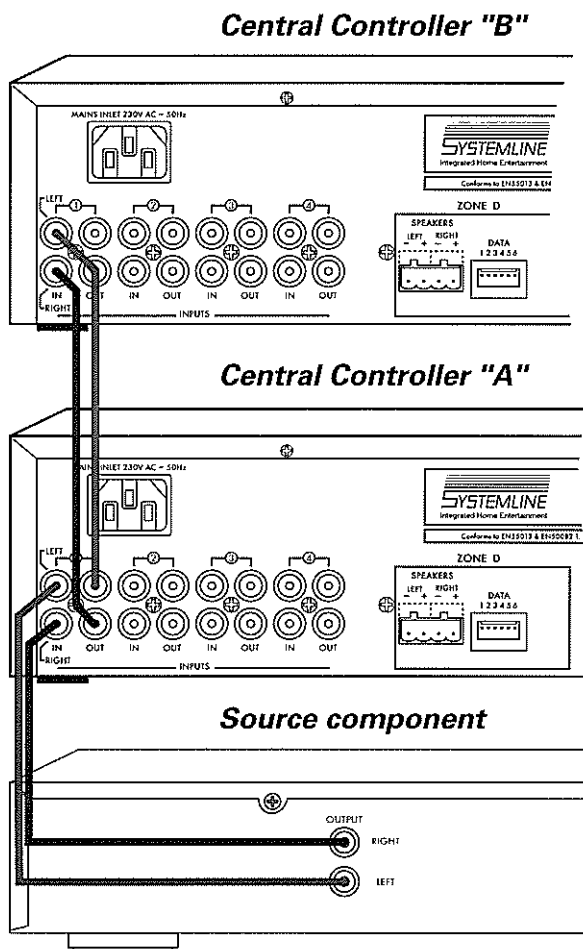

If a system requires a third Central Controller, simply repeat this procedure but, this time, connect source output on Central Controller "B" to the corresponding input on Central Controller "C".

NOTE: It is doubly (or trebly) important to observe proper channel continuity when connecting source components to more than one Central Controller. Once again, BE PATIENT AND BE CAREFUL.

5.24 IR Flood Emitter Connections

When 2 or 3 Central Controllers are used in the same system, we suggest that you connect them so that only one IR "flood" emitter works. This avoids potential interference that may lead to erratic operation.

Note that this is a suggestion only and not a hard and fast rule. There may be some system layouts which benefit from the increased signal strength from all IR "flood" emitters. Experiment as needed. Use the following connection guide for multiple Central Controller systems:

a) For 5-8 Zone systems (2 Central Controllers):

- Remove the jumper between terminals 2 and 3 of the TX FORMAT block on Central Controller "A" but leave the jumper in place on Central Controller "B".
- Connect terminal 3 of Central Controller A's TX FORMAT block to terminal 4 on Central Controller "B".

This completes the signal link to the IR "flood" emitter on Central Controller "B".

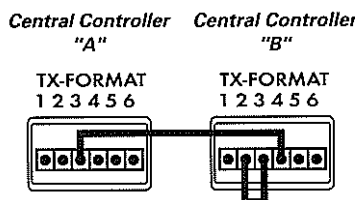

Use this jumper arrangement in a system with 2 Central Controllers to disable the flood IR emitters on the first controller and enable the emitter on the second.

- To activate BOTH IR "flood" emitters, connect terminal 2 on Central Controller "B" to terminal 2 on Central Controller "A"

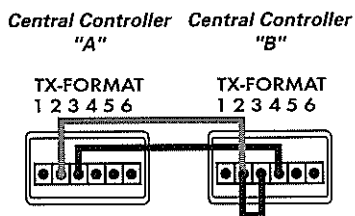

Use this jumper arrangement in a system with 2 Central Controllers to enable the flood IR emitters on both Central Controllers.

NOTE: To disable both IR "flood" emitters, simply remove the jumper between terminals 2 and 3 of Central Controller "B". Also disconnect any link between terminal 2 of both "A" and "B".

b) For 9-12 Zone systems (3 Central Controllers):

- Remove the jumpers between terminals 2 and 3 of the bottom two Central Controller's TX FORMAT blocks (Central Controller "A" and "B") but leave the jumper in place on Central Controller "C".
- Connect terminal 3 of the Central Controller "A" TX FORMAT block to terminal 4 on Central Controller "B".
- Connect terminal 3 of the Central Controller "B" TX FORMAT block to terminal 4 on Central Controller "C".

This completes the signal link to the IR "flood" emitter on Central Controller "C".

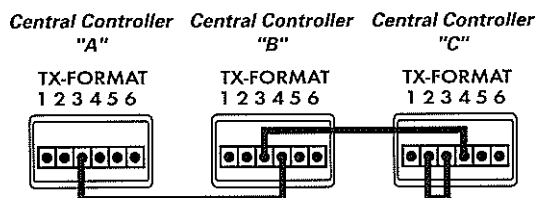

Use this jumper arrangement in a system with 3 Central Controllers to disable the flood IR emitters on the first two Controllers and enable the emitter on the third.

- To activate ALL IR "flood" emitters, connect terminal 2 on Central Controller "C" to terminal 2 on Central Controller "B". Then connect terminal 2 on Central Controller "B" to terminal 2 on Central Controller "A".

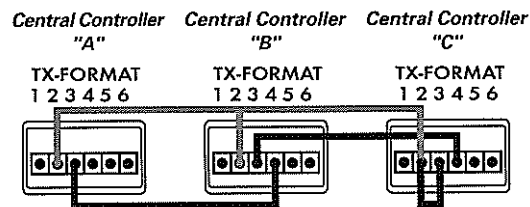

Use this jumper arrangement in a system with 3 Central Controllers to activate the flood IR emitters on all three Controllers.

NOTE: To disable all IR "flood" emitters, simply remove the jumper between terminals 2 and 3 of Central Controller "C". Also disconnect any link between terminal 2 of "A" and "B" and "C".

5.25 IR Repeater Connections

Use the following connection guide for multiple Central Controller systems:

- a) For 5-8 Zone systems (2 Central Controllers): Make sure to connect all IR repeaters to only Central Controller "B". Make all RC-5 connections, if needed, to only Central Controller "B".
- b) For 9-12 Zone systems (3 Central Controllers): Make sure to connect all IR repeaters to only Central Controller "C". Make all RC-5 connections, if needed, to only Central Controller "C".

5.26 Note on "Engaged" Indicator

The "Engaged" indicator on a remote zone's IMS Display/Eye(s) will indicate other same-source users only in zones connected to that particular Central Controller.

For example, in an 8-zone system using two Central Controllers, a CD listener in Zone 7 (connected to the second Central Controller) would have no indication that another user in Zone 2 (connected to the first Central Controller) was listening to the same source. If a third listener in Zone 4 then selected CD, only the listeners in Zones 2 and 4 (both connected to the same Central Controller) would know that someone else was sharing the same source.

6.1 Preliminary Observations

Once properly installed and set up, the Central Controller Multi-Room System is easy to use and operate.

The Central Controller should ALWAYS be plugged into an uninterruptable AC source. This ensures that essential Central Controller system benefits such as remote controlled zone activation and source selection are always available.

The IMS Display/Eye is powered from the data cables and are always active as long as the Central Controller is connected to an AC source and switched on.

6.2 System Start-up

When all the wiring is complete and has been checked for short circuits, you may follow the switch on procedure below:

- 1) Switch on all source components and press play buttons for both the CD player and tape deck.
- 2) Switch on Central Controller.

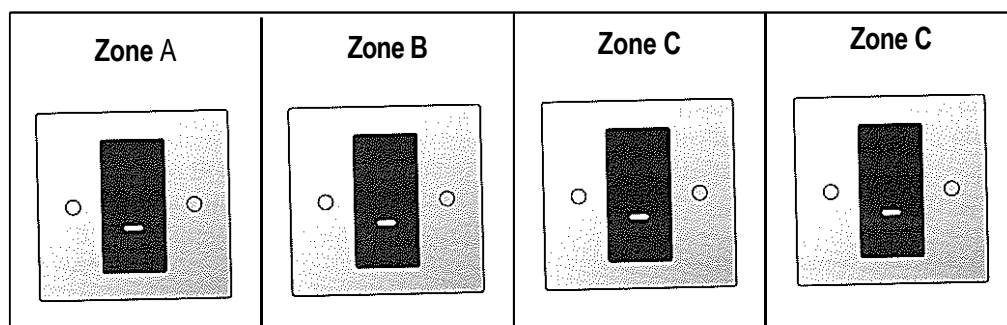
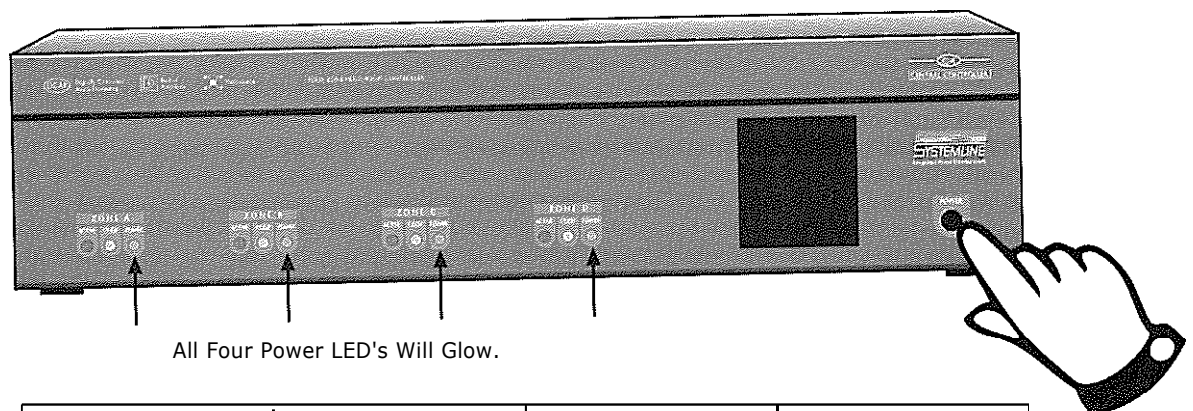

Select any of the four inputs to switch a zone "ON". To switch "OFF" select standby. When switched "ON", the zone volume will be at a low but audible level. Volume can now be adjusted. When switched "OFF", the zone volume will ramp down gently until zero volume, at which point a relay will fully disconnect the speaker output.

6.3 System Status

Zone 'A'

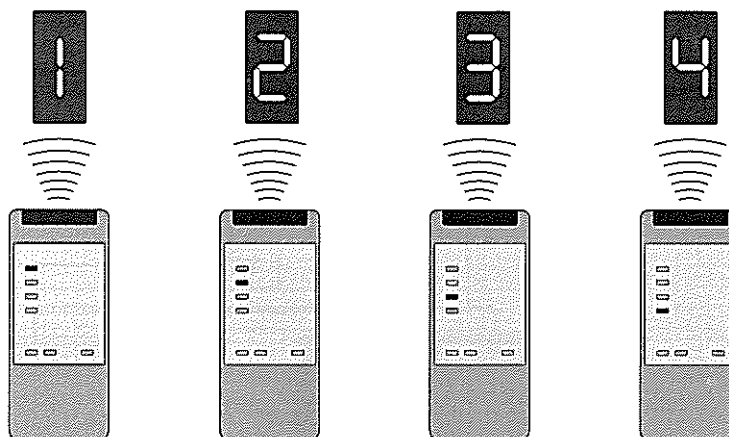
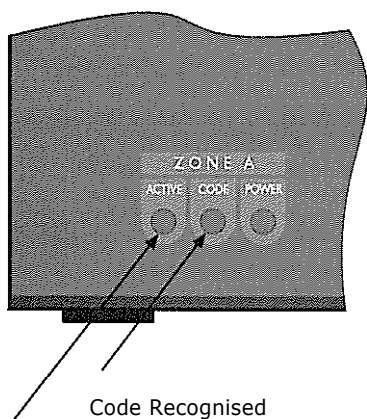

Zone Active

As input selection button pressed, the "Active" LED on Central Controller will illuminate. The 'Code' LED will flash on recognition of any of the seven command functions from the fixed code handset and stereo sound will be heard through the speakers for each of the inputs selected.

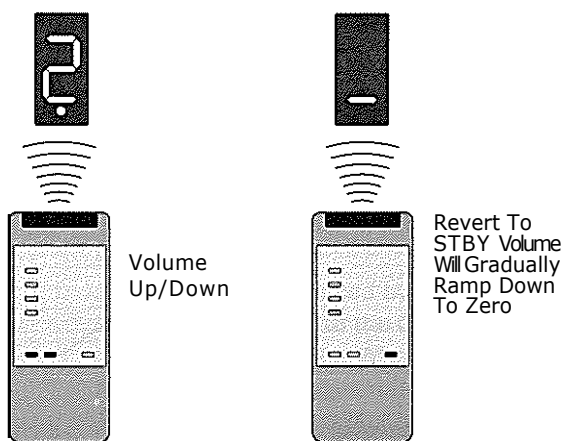

Zones B, C & D As Per Zone A

6.31 Engaged Indication

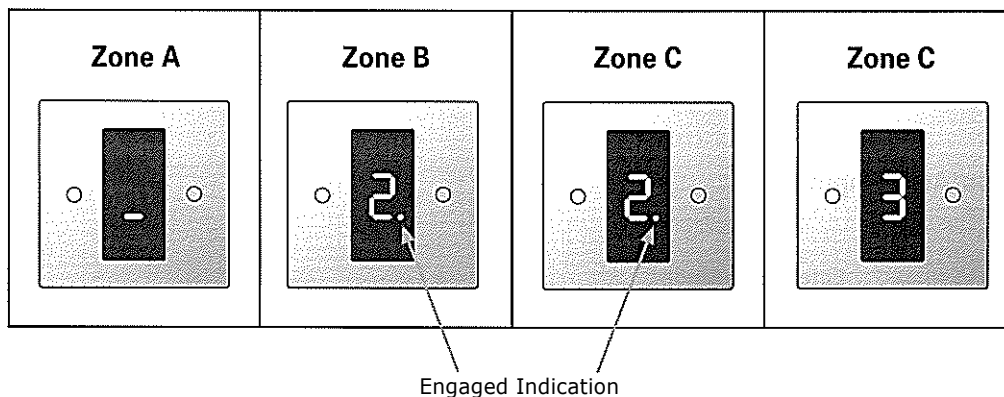

When the same source is selected in two or more different zones, a small LED will glow alongside the source number.

This is to let the respective users know that more than one person is listening, making it impolite to change stations or tracks, etc. Volume, however, remains independent (See also section 5.26).

6.4 Teaching the SC-LH Learning Handset

The Central Controller codes using the Fixed code handset. (See also the supplied Learning handset instruction booklet).

Tuner = Input 1

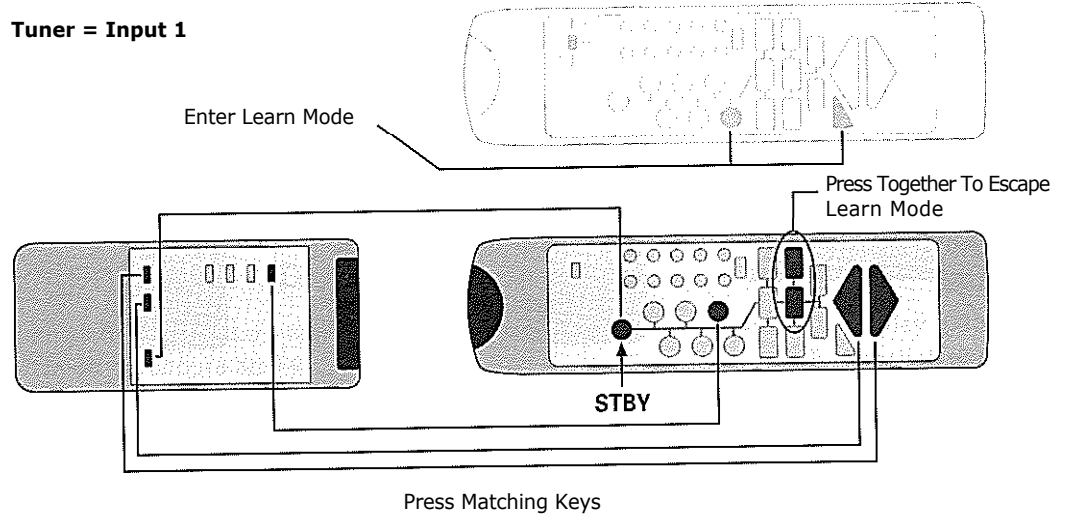

CD = Input 2

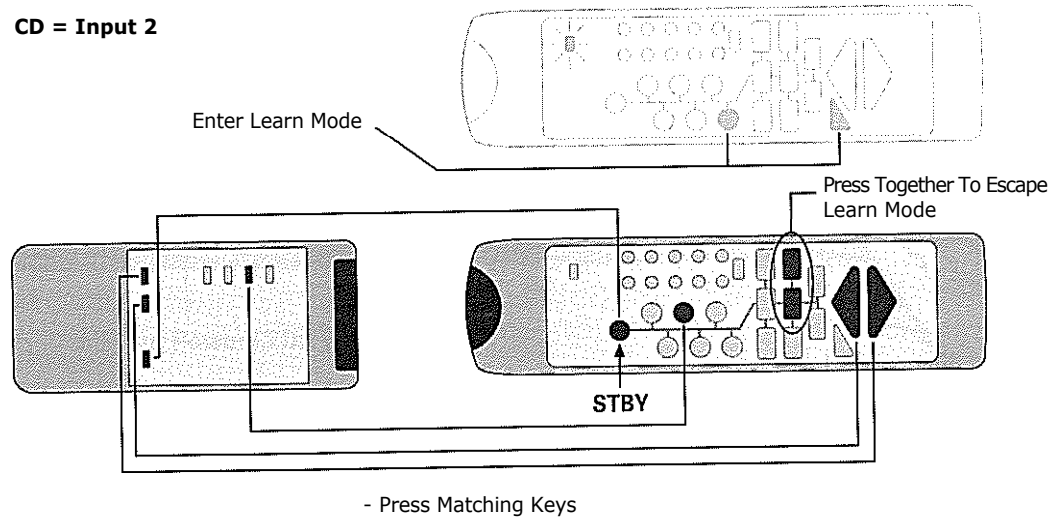

Tape/Aux = Input 3

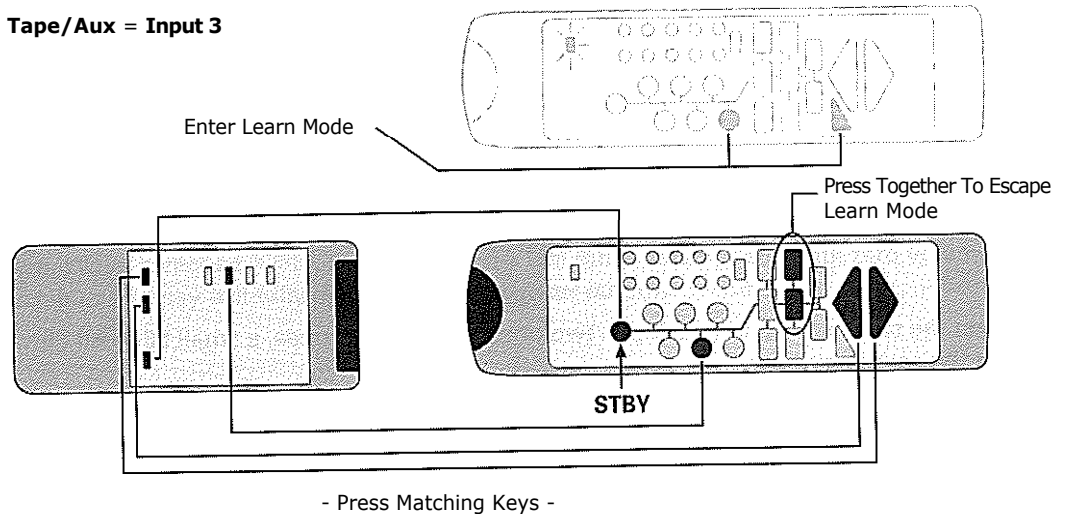

Video = Input 4

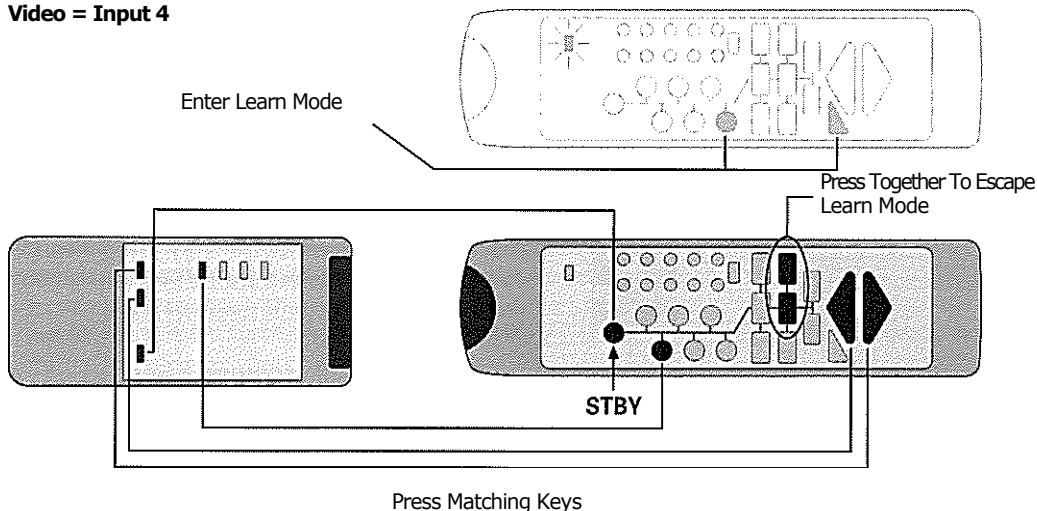

NOTE: The Learning Handset is pre-programmed for RC-5 (Philips) codes and will therefore immediately operate a number of manufacturers TV and Hi-Fi products.

If, however, any of your source components do not operate on the RC-5 code system, it is often possible to teach the Learning Handset alternative manufacturer's codes by following the Learning Handset instruction booklet.

Neither QED AUDIO PRODUCTS LTD nor PHILIPS CONSUMER ELECTRONICS guarantee that the Learning Handset will learn all codes, it is therefore vital to verify compatibility prior to choosing source equipment.

6.41 Using the Learning Handset

The Central Controller functions operate in the same way as with the Fixed Code Handset; however, there is a slight delay on the operation of all source selection buttons on the Learning Handset. Refer to Display/Eye for confirmation of operation.

Infra-red codes received by the Display/ Eye are transferred to the Central Controller via a data wire. When input selection is received, a code is sent back to the Eye to display the correct input designation. This method is also used to convey the Engaged code. If a code is sent to tell, for example, a CD player to 'skip track', this code is retransmitted from the flood infra-red window on the front of the Central Controller*, and received and acted upon by the CD player. This works the same way as it would if it received the code directly from the original handset.

* or Window Emitter or Direct RC-5 Output

6.5 Operating Source Components Via Systemline

After Switch On Display/Eye Will Show Input Selected

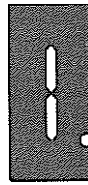
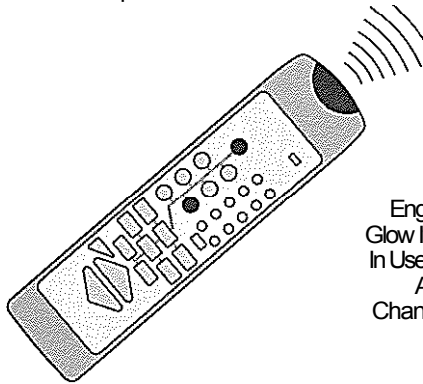

Engaged LED Will Glow If Tuner Is Also In Use Elsewhere To Advise Against Changing Stations.

6.51 Using the Tuner

- 1) To switch ON, requires only one button to be pressed, after which volume can be adjusted as required.
- 2) To change radio stations, just press one of the ten pre-set channel buttons.
- 3) To switch OFF, press the STANDBY button.

After Switch On Display/Eye Will Show Input Selected

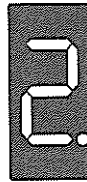
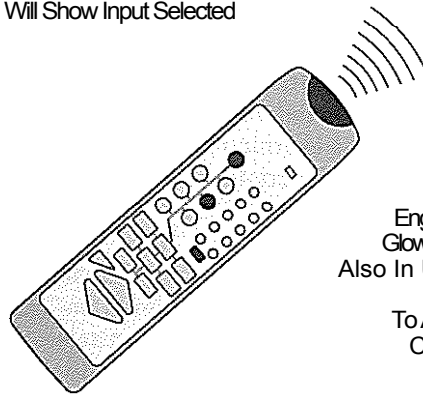

Engaged LED Will Glow If CD Player Is Also In Use Elsewhere To Advise Against Changing Discs.

6.52 Using the CD Multi-Player

- 1) To switch ON, press CD button followed by PLAY button, after which adjust volume as required.
- 2) Other functions such as skipping tracks, etc, can be carried out using the other function buttons.
- 3) There is no specific button on the Philips Learning Handset for 'Disk Skip', We therefore recommend that the code is programmed into the '-/-' button.
- 4) To switch OFF, first press the STOP button followed by the STANDBY button.

After Switch On Display/Eye Will Show Input Selected

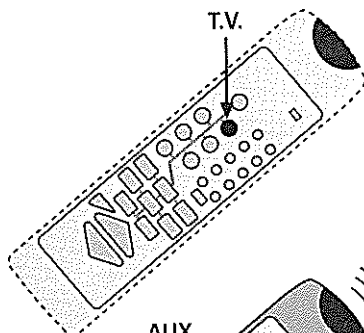

Engaged LED Will Glow If Satellite Player Is Also In Use Elsewhere To Advise Against Changing Satellite Channels.

6.53 Using an A/V Source

(e.g. Satellite Receiver)

- 1) Press TV button on handset followed by Satellite channel (e.g. Ch 5). These functions can be carried out either with the original TV handset or using the Learning Handset.
- 2) Now press AUX button followed by the number of the Satellite Channel you want. The correct programme should now appear on the TV screen together with Hi-Fi stereo sound via Systemline. Adjust the volume.
- 3) To switch OFF, press STANDBY button and the sound will cease. Now press the TV button followed by STANDBY to switch off the TV (or use original TV handset).

IMPORTANT NOTICE

All six input buttons on the Learning Handset, TV, VIDEO, CD, AUX, CD, TUNER & TAPE have a built in operating delay, refer to the DISPLAY/EYE to confirm that the input is selected.

6.6 Using The SC- FH Fixed Code Handset

This is useful in areas where simplicity is more important than full functionality, or where restricted access to Systemline is required—a child's room, for example, it is also used to teach the Learning Handset.

6.61 Key Operating Points

All zones (rooms) operate completely independently both in terms of source selection and volume levels.

This means that it is possible to listen to four different sources in four different rooms at four different volume levels—simultaneously!

When the Engaged LED appears, it does not "lock out" the user, it is merely a "polite notice" of what's happening elsewhere.

When a zone is switched to STBY, the infra-red relay is inhibited.

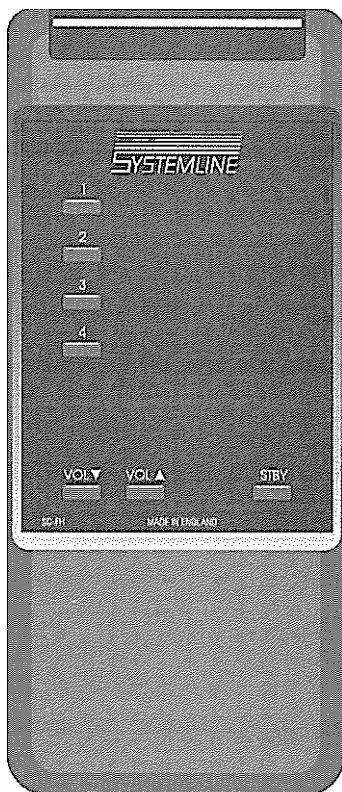

6.7 IMS Display/Eye

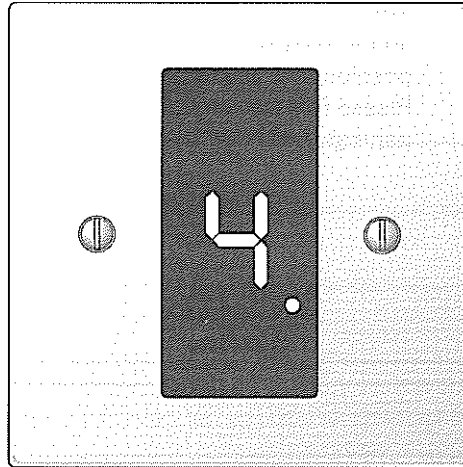

6.71 Overview

The IMS Display/Eye receives IR signals from the hand held remote and other IR devices. In addition, it provides feedback on system status through an LED display matrix mounted behind the cover plate.

The LED display supplies the following data: System status: The Standby bar "-" indicates that the Zone is in Standby Mode. To reactivate the zone, simply press the input of the source you wish to hear.

Tuner	Input 1
CD player	Input 2
Tape Deck/Sat. receiver	Input 3
Video/Laser disc	Input 4

If there is no display symbol this indicates that the Central Controller is OFF and will need to be turned ON at the main control unit before use.

When initiating an ALL ZONES OFF command, the Standby bar will flash twice.

7.0 Conclusion

We hope this manual has been of assistance in planning and installing your multi-room sound distribution system. Although we've gone to great lengths to make this as complete as possible, we're sure we haven't covered every aspect of every possible system installation. Please feel free to call our Technical Support Department on (01276) 451166 or Email panic@ged.co.uk if you have any questions. Thank you very much.

QED FAX BACK

FAX TO: (01276) 452211

SOURCE COMPONENT COMPATIBILITY PROBLEM

Installer/Dealer Name:
Your Fax Number:
Your Telephone Number:
Controller Serial Number:
1st Component Type (CD, etc.)
Brand (SONY, Denon, etc.)
Model Number:
Details of problem....
2nd Component Type:
Brand:
Model Number:
Details of problem....
3rd Component Type:
Brand:
Model Number:
Details of problem....
Any other comments: